

Serie F.500



RUBBER EXPANSION JOINT

F.500



Rubber expansion joints protect the piping from extension, compression, misalignments and bending. Suitable for reducing vibrations and noise absorption, allowing the further reduction of the effects of water hammers

YES: for water plants, pumping stations, conditioning and heating, industrial and agricultural applications, compressed air circuits.

Application fields



WATER



CONDITIONING



INDUSTRY



HEATING



DRINKING WATER



www.bkvvana.com

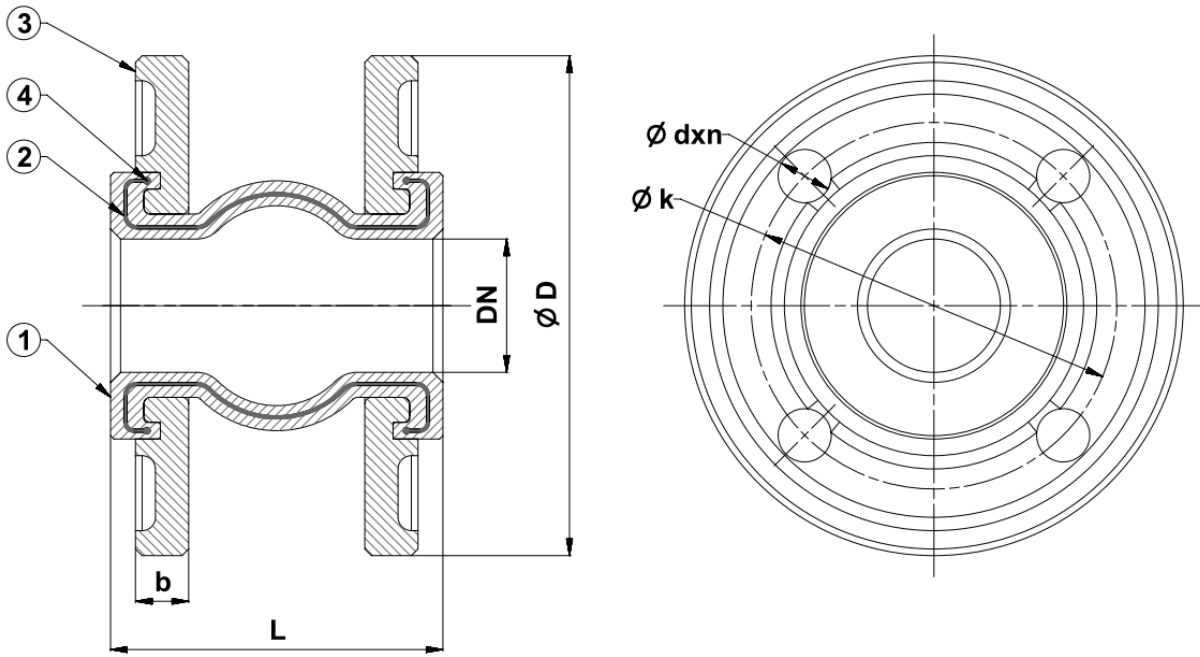

Materials

	Component	Material
1	Body	EPDM
2	Kord Fabric	Nylon 6.6
3	Flange	Steel ST37
4	Piston Ring	Carbon Steel

Dimensions (mm)

DN	32	40	50	65	80	100	125	150	200	250	300	350	400	450	500	600
L	95	95	105	115	135	150	165	180	210	230	245	255	255	255	255	260
ØD	140	150	165	185	200	220	250	285	340	405	460	520	580	640	715	840
Axial Expansion	+6mm		+7mm		+8mm	+10mm	+12mm		+16mm							
Axial Compression	-9mm	-10mm		-13mm	-15mm	-19mm		-20mm		-25mm						
Lateral Movement	9mm		10mm	11mm	12mm	13mm		14mm		22mm						
Angular Movement	15°															
k	100	110	125	145	160	180	210	240	295	355	410	470	525	585	650	770
b	16		18		20		22		24	26	26	28	28	28	30	32
dxn	18x4	18x4	18x4	18x4	18x8	18x8	18x8	22x8	22x12	26x12	26x12	26x16	30x16	30x20	33x20	36x20

Weight (kg)

	3.2	3.6	5	6.4	7.2	8.2	10.8	13	19	27	38.5	47	55	69	82	130
--	-----	-----	---	-----	-----	-----	------	----	----	----	------	----	----	----	----	-----

Certificates



Standards

Design : TS EN 10879
 Flange Dimensions : TS EN1092-2 (PN 16)
 Tests : TS EN 12266-1
 Nominal Pressure: PN16
 Temperature: -20 ~ 90°C

Versions

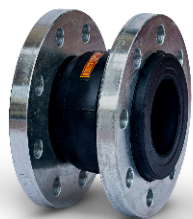

F.500

Body: EPDM
Flange: Steel ST37
PN16

F.500.1

Body: EPDM
Flange: Stainless Steel 304
PN16

F.500.2

Body: EPDM
Flange: Stainless Steel 316
PN16

F.500.3

Body: EPDM
Flange: Steel ST37
PN25

F.500.4

Body: EPDM
Flange: Stainless Steel 304
PN25

F.500.5

Body: EPDM
Flange: Stainless Steel 316
PN25

Accessories

Control rod unit

Control rod unit in galvanized carbon steel

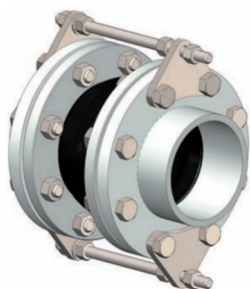

Instruction and Recommendations

STORING

- Keep in dry and closed place.
- Avoid exposure to direct sunlight.

INSTALLATION

- Control rods should be installed in case movement exceeds the values permitted, indicated in the product specifications. The use is recommended when there are pumps or other devices being installed on springs or other elements not fixed or supported.
- Warning. Install the rubber joint respecting its unloaded length. Compression or elongation deformation imposed during joint installation could reduce performances and cause early wear and damages to joint.
- Clean the surface before bringing the rubber and the flange into contact;
- Ensure that protrusions and sharp edges on the piping do not cause damage to the contact surface of the joint;
- Do not weld the flanges to the piping after installing the joint. Joints must be protected against sparks from any welding/grinding jobs carried out nearby.
- Fit the screw to the flange, with the head of the screw in the direction of the joint, to protect the rubber from damage (Fig. 1). Tighten the bolts crosswise.
- Do not install the joint in direct contact with a rubber surface (for example, butterfly valves).

- Do not place gaskets between the joint and counter flange.
- Avoid exposure to direct sunlight. In the case of installing outside, protect the joint, if necessary.

FIG.1

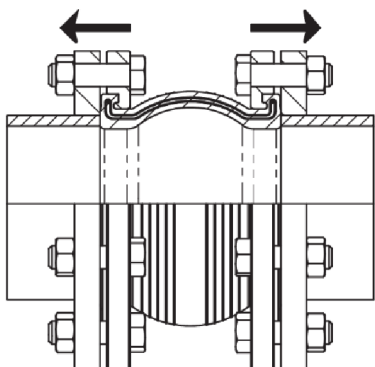
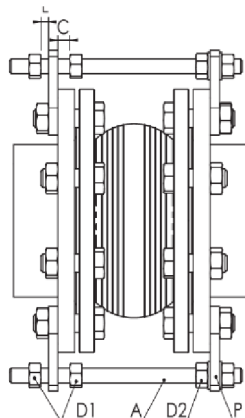

FIG.2



INSTALLATION OF THE CONTROL ROD UNIT

1. Install the plates, P, on the counter flange (fig. 2)
2. Fasten rod A to the plate with two nuts on one side (for example, D2 – fig. 2).
3. On the opposite side, regulate the distance between the nuts (D1) and the plate, thereby the extension (L) and the compression limits (C) allowed for the joint.

Do not exceed the maximum allowed values, indicated in the product specifications.